

Table Top Ballista Plan



22AD Plans & Kits are produced by
Dolphin Foundry
Featherston, New Zealand
www.22ad.co.nz

SCALE 1:2

All dimensions are in millimeters.

Full sized parts patterns for some parts
are included on a separate sheet for cutting.

All parts are stock 18mm
square unless otherwise stated.

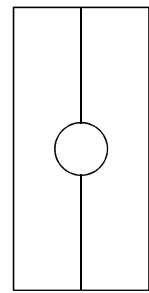

Outer torsion frame braces have a
cutout for the throwing arms.

Clamp the two together and drill to
make the cutouts as shown

Cutouts in the top and bottom torsion
frames can be made the same way

Outer torsion frame braces are
held by dowels and NOT glued
so they can be removed for
tightening the rubber bands

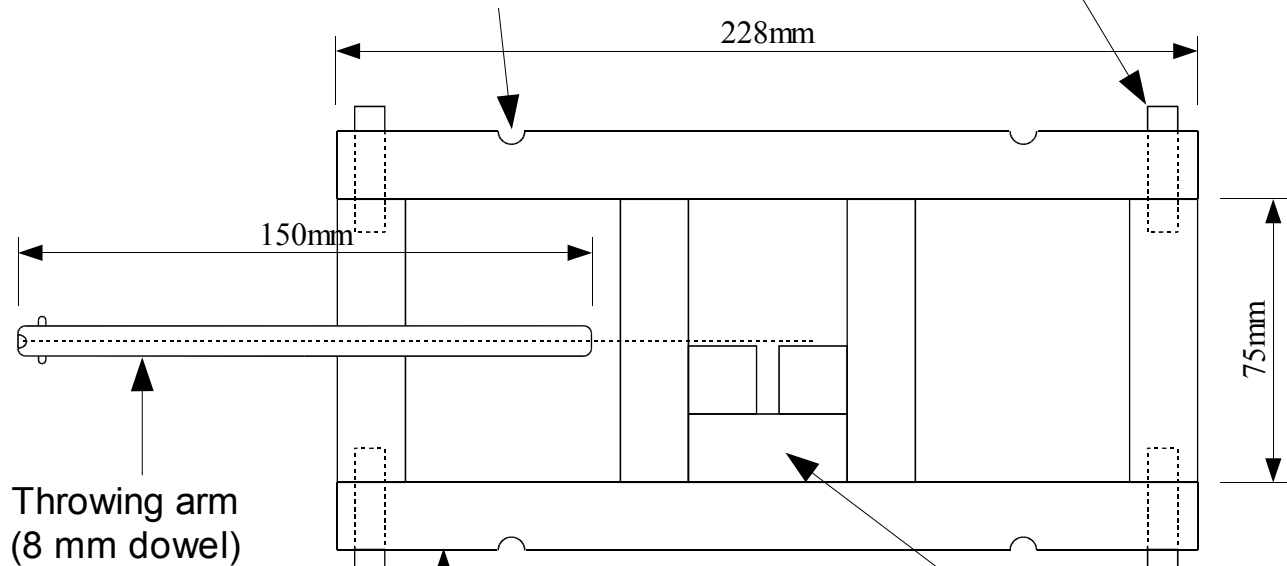

Throwing arm
(8 mm dowel)

Torsion Frame

Launching tray base
(40mm X 20mm)

Stand

Front Brace
(4.7mm sheet)

300mm

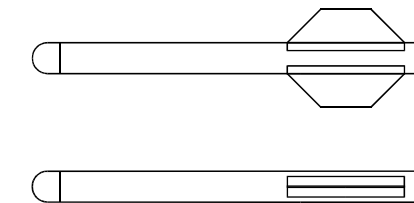
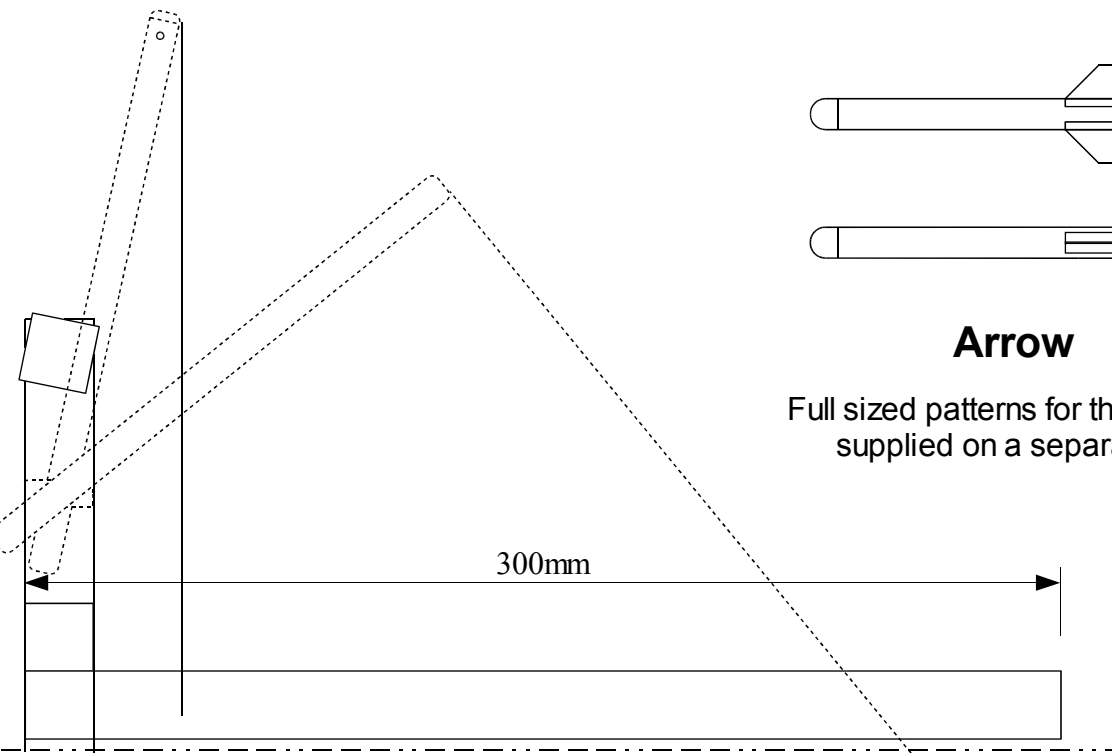

Arrow

Full sized patterns for the arrows are
supplied on a separate sheet

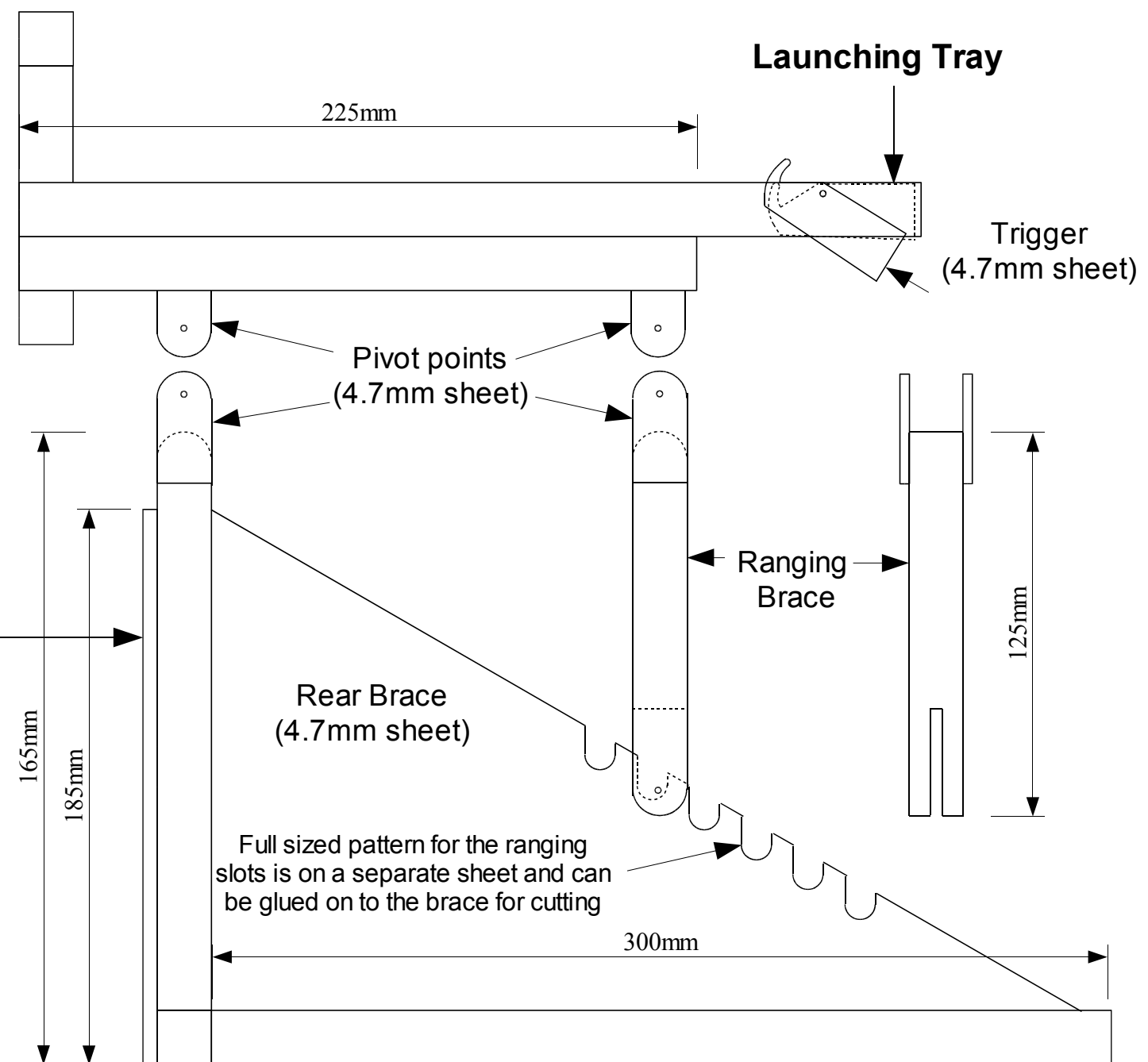

Launching Tray

Trigger
(4.7mm sheet)

Pivot points
(4.7mm sheet)

Ranging
Brace

Rear Brace
(4.7mm sheet)

Full sized pattern for the ranging
slots is on a separate sheet and can
be glued on to the brace for cutting

165mm

185mm

125mm

300mm

225mm